

1. Technical parameter

Measuring range	0.00...20.00mg/L
Resolution	0.01mg/L
Accuracy	±0.2%FS
Temperature range	0...60.0°C
Resolution	0.1°C
Accuracy	±0.2°C
Pressure range	0...2bar
Medium flow rate	> 0.02m/s
Shell material	PC,316L
Output	RS485;4...20mA
Power supply	9-30VDC(Recommend 12V)
Thread	3/4NPT,M39*1.5
Cable length	5m or customize
Sensitivity	±0.05% of range
Protection grade	IP68

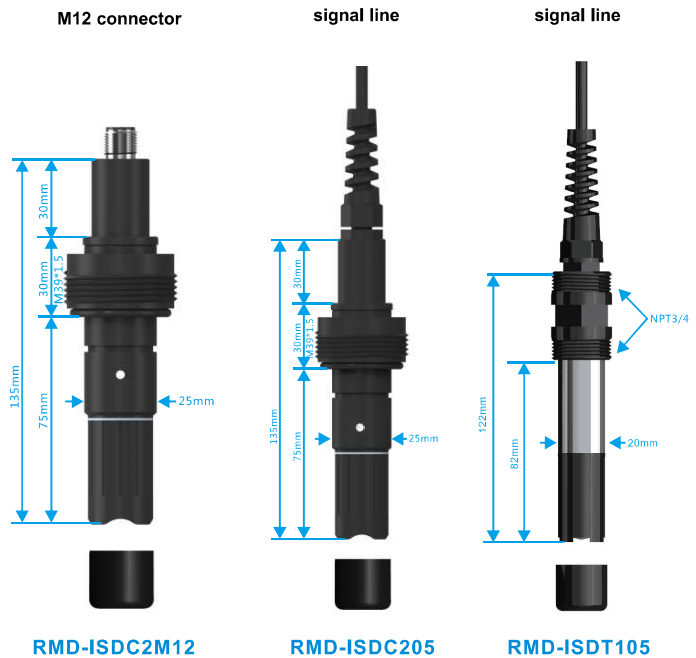

2. Before use

- 2.1 Please read this instruction carefully before use.
- 2.2 The sensor head is a fragile item and cannot be repaired once it is damaged.
- 2.3 Before using the electrode, the protective cover should be gently removed and placed in the solution to be tested for polarization for more than 4 hours (see Section 5 for polarization method).
- 2.4 Not adding electrolyte can result in inaccurate or fluctuating measurements
- 2.5 If the electrode is stored in air for more than 2 hours after adding electrolyte, it will cause damage to the cap, inaccurate measurement or fluctuation.
- 2.6 In the measurement process, if there is dirt, adhesive or scale on the electrode membrane head, the measured value will not be accurate or fluctuate. It should be cleaned and calibrated in time.
- 2.7 If there are bubbles in the membrane head, the measured value will be inaccurate or fluctuate.
- 2.8 Privately extend, cut short, force pull signal line and joint, etc., will result in inaccurate or unsteady measurement.

3. Electrode wiring

- 3.1 Please follow the instructions carefully and the wrong wiring will result in complete damage to the product.
- 3.2 It is forbidden to send power before all cable connections are completed, so as to avoid danger. Please carefully check all the wiring of the system before sending power, and confirm that it is completely correct before sending power.

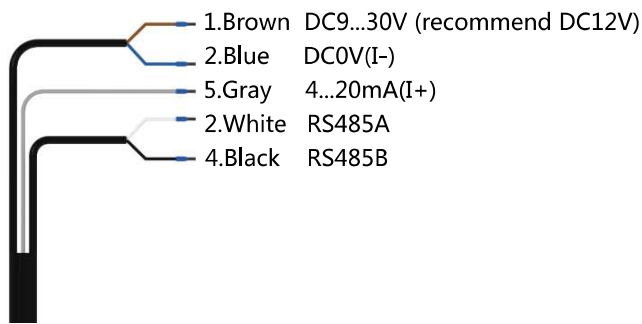

Electrode outlet

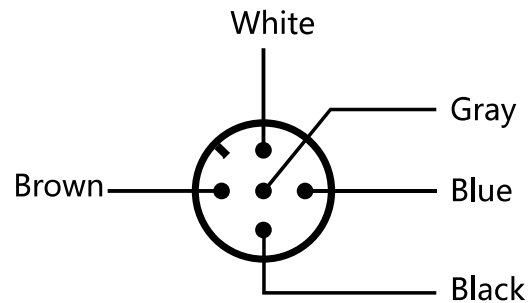

M12 connector

4. Add electrolyte and replace the membrane head

- 4.1 The new electrode is added with electrolyte, and users are recommended to check before use.
- 4.2 It is recommended that the user should replace the electrolyte every three months, but the actual operation should be subject to the specific use of the measured medium and electrode.
- 4.3 If the electrode signal is abnormal (long response time, mechanical damage, too large in zero oxygen water, too large in air, too small, etc.), the membrane head needs to be replaced, the common oxygen membrane is replaced every 6 to 12 months, and the empered oxygen membrane is replaced every 18 to 24 months.
- 4.4 The procedure for replacing the membrane head and adding electrolyte is shown below.

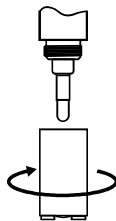

Disconnect the power supply, turn counterclockwise, remove the membrane head smoothly, and pour the residual electrolyte inside the membrane head into the waste solution pool.



Tilt the membrane head, and the electrolyte bottle is vertically downward. Gently squeeze the electrolyte bottle, so that the electrolyte slowly flows into the membrane head until it is full.

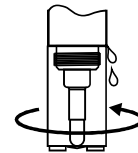

Slowly rotate the membrane head clockwise into the inner core of the electrode until the liquid beads flow out. Repeat 3 times of tightening and loosening to completely discharge the air and make the membrane close to the electrode cathode.

5. Electrode polarization

- 5.1 Polarization method : connect the electrode to the transmitter , put the electrode into the solution to be tested , and connect the power supply. After the power is turned on, the polarization starts.
- 5.2 The electrodes need to be polarized in the following cases.
- ☞ When the electrode is first used, it will polarize for more than 4 hours ;
 - ☞ Replace the membrane head or electrolyte and polarize for more than 4 hours;
 - ☞ The transmitter is powered off, or the electrode is disconnected from the power line. See the table for polarization time.

	power-off time t1	Minimum polarization time t2
1	t1 ≤ 5	2*t1
2	5 < t1 ≤ 15	4*t1
3	15 < t1 ≤ 30	6*t1
4	t1 > 30	360

6. Electrode calibration

- 6.1 The instrument has been calibrated before shipment, and the user can directly use it. Online monitoring of the measured medium should maintain a constant flow rate, flow rate > 0.02m / s.
- 6.2 The calibration of dissolved oxygen electrode is performed by zero oxygen calibration and full degree calibration, Before the calibration, ensure that the cable is connected to the instrument for more than 4 hours.
- 6.3 Users are recommended to calibrate every 1 to 2 months.

7. Electrode installation

- 7.1 The dissolved oxygen electrode is recommended to be installed in the flow cell for more stable and accurate measurement.
- 7.2 Installation method.

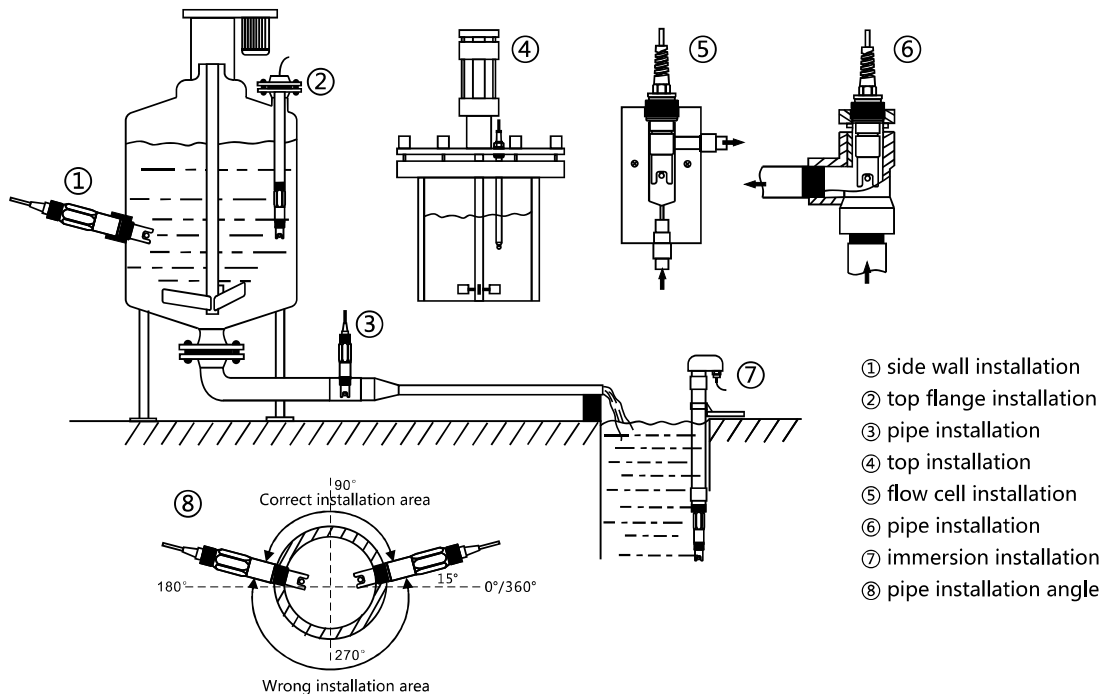

Immersion installation requires attention:

1. This kind of installation is prone to scale formation during the measurement process and needs to be cleaned regularly.
2. Measurement is uneven.
3. Different insertion depths will affect the measured value.
4. The position of the probe must be above the sediment.

8. Electrode communication

8.1 Address description

Name	Hosting number	Data type	Length	Read/write	Description
Measurements	0X 00 01	floating point	2	read	Measure storage location
Temperature measurement	0X 00 03	floating point	2	read	Measure temperature storage location
Current output value	0X 00 05	floating point	2	read	Output current based on DO measurements
warning	0X 00 07	Integer	1	read	01: Measurement exceeds the upper limit; 02: Measurement exceeds the lower limit 03: Temperature exceeds the upper limit; 04: Temperature exceeds the lower limit
Measurement mode	0X 00 08	Integer	1	read/write	Default value:%; 00:% 01:mg/L
Upper limit of measurement	0X 00 0A	floating point	2	read/write	Default value 200%;Upper limit of measured value (20mA corresponding value)
Lower limit of measurement	0X 00 0C	floating point	2	read/write	Default value 0;Lower limit of measurement value (4mA corresponding value)
Upper temperature limit	0X 00 0E	floating point	2	read/write	Default value 60°C;Upper temperature limit
Lower temperature limit	0X 00 10	floating point	2	read/write	Default value 0°C;Lower temperature limit
Measured value offset	0X 00 12	floating point	2	read/write	Default value 0;Corrected measurement
Temperature offset	0X 00 14	floating point	2	read/write	Default value 0;Corrected temperature value
Damping coefficient	0X 00 16	Integer	1	read/write	Default value 0; 0-10
Device address	0X 00 19	Integer	1	read/write	Default value 01; 1-255
Baud rate	0X 00 1A	Integer	1	read/write	Default value 9600; 0=2400 , 1=4800 , 2=9600 3=19200 , 4=38400
Restore Factory	0X 00 1B	Integer	1	write	
Pressure compensation	0X 00 30	floating point	2	read/write	1013BAR
Salinity compensation	0X 00 24	floating point	2	read/write	0.0
Correction slope	0X 00 2C	Integer	2	read	-0.1984
Manual temperature	0X 00 3A	floating point	2	read/write	25°C
Zero correction	0X 00 3E	Integer	1	write	
Slope correction	0X 00 3F	Integer	1	write	
Measuring ADC	0X 00 66	Integer	1	read	

8.2 Communication description (factory default):

factory default	
baud rate	9600
data bit	8
stop bit	1
check bit	no
address	1 (default)

8.3 Host computer transmission format

	ID address	Function	Data address		Data content		CRC16	
	Slave ID	Function	Address_H	Address_L	Quantity	Quantity	CRC_L	CRC_H
length	1byte	1byte	1byte	1byte	2byte	2byte	1byte	1byte
Example 1 Read measured value	0X 01	0X 03	0X 00	0X 01	0X 00	0X 02	0X 95	0X CB
Example 2 Read Temp value	0X 01	0X 03	0X 00	0X 03	0X 00	0X 02	0X 34	0X 0B

8.4 Slave computer response format

	ID address	Function	Data Qty	Data content		CRC16	
	Slave ID	Function	Quantity	Data_L	Data_H	CRC_L	CRC_H
length	1byte	1byte	1byte	2byte	2byte	1byte	1byte
Example 1 Measured value return	0X 01	0X 03	0X 04	0X 2C 81	0X 40 91	0X 52	0X E7
Example 2 Temp value return	0X 01	0X 03	0X 04	0X 72 37	0X 41 DB	0X 20	0X BE

Note: 1. Data starting at 0x represents hexadecimal

2. The check code is 16CRC, the low byte is in the front and the high byte is in the back.

3. Floating point occupy four bytes

4. Data content Data_L and Data_H transposition to Data_H, Data_L, that is, measure value 40 91 2C 81, and convert to floating point 4.53; The temperature return value 41 DB 72 37, converted to floating point 27.4.

9.Maintenance, care and storage

9.1 The electrode should be cleaned regularly with deionized water. The oxygen-permeable membrane should not be broken when disassembling and rinsing the electrode. The oxygen-permeable membrane on the electrode should not be wiped with filter paper or sandpaper.

9.2 When the membrane head is fouled and clogged, the electrolyte is dry, lacking or the electrolyte is contaminated, it should be stopped and the membrane head removed.

9.3 After cleaning the electrode, replacing the membrane head, adding electrolyte, and after long-term storage, it needs to be polarized and calibrated before continuing to use.

- 9.4 The cable connector must be kept clean, dry, free from moisture, water, or contact with acids, alkalis, salts, etc.
- 9.5 When the water or electrode is cut off on site, the electrode should be taken out, cleaned and covered with protective sleeve containing water for preservation; When the electrode is not used for a long time, it needs to be stored for a long time. Remove the electrode, disconnect the meter, drain the electrolyte, thoroughly clean the anode and the anode with deionized water at 30 °C~40 °C, dry it and put on the protective cover. Place it in a dry place for storage.

10.Troubleshooting

- 10.1 When the measurement is not accurate, the failure rate of the general instrument is low, The condition of dissolved oxygen electrode has changed, so it is necessary to check whether the dissolved oxygen electrode is in good condition.And the dissolved oxygen electrode is not easy to damage, generally the membrane head damage, scaling, electrolyte pollution or loss, etc. need to replace the membrane head or add electrolyte.
- 10.2 If the value of the instrument is too large, too small or no change, check whether the electrolyte is dry, missing or contaminated. If the above conditions occur, re-add the electrolyte; Check whether the electrode is in good condition with the instrument connection line or joint.
- 10.3 Modbus troubleshooting:

Problem	Possible reason	Solution
Modbus no response	The baud rate, or stop bit does not match the Modbus master settings	Verify that the Settings match the Modbus master device Settings, and verify that the Modbus master device parity check is set to None
	Rs232 or RS485 cable is faulty	Replace/repair cables
	No network offsets and terminations, or network offsets and terminations are not suitable.	Check the termination or offset Settings for all network devices. Only the endpoints of the network should be turned on and terminated, and there should be only a point on the network to provide an offset.
	The slave address is incorrect, or the slave address is the same as the address of another bus device	Verify that all addresses are unique and are between 1 and 247.
Modbus abnormal response	Register not supported	Verify that the register is supported
	Incorrect data type	Verify that the requested register data type matches the Modbus master device request; for example, you cannot access a floating point data using 2-byte integer data. When a floating point data (2 registers /4 bytes) is requested, two registers must be requested at the same time.